

## Device marker - LS-EMSP-V4A (75,6X54) - 0831656

Please be informed that the data shown in this PDF Document is generated from our Online Catalog. Please find the complete data in the user's documentation. Our General Terms of Use for Downloads are valid (<http://phoenixcontact.com/download>)

Device marker, Stainless steel label, silver, unlabeled, can be labeled with: TOPMARK NEO, TOPMARK LASER, mounting type: screw, rivet, lettering field size: 75.6 x 54 mm, Number of individual labels: 6



### Your advantages

- Stainless steel device marking for screwing or riveting



### Key Commercial Data

Packing unit	5 pc
Minimum order quantity	5 pc
GTIN	
GTIN	4046356925952

### Technical data

#### Dimensions

Length (b)	53.7 mm
Width (a)	85.6 mm
Hole diameter	3.20 mm

#### Ambient conditions

Ambient temperature (operation)	-80 °C ... 400 °C
---------------------------------	-------------------

#### General

Color	silver
Components	free from silicone, halogen, and cadmium
Material	V4A
Wipe resistance	DIN EN 61010-1 (VDE 0411-1)
Number of individual labels	6
Printability	Direct laser marking
Device	1012015 TOPMARK NEO

# Device marker - LS-EMSP-V4A (75,6X54) - 0831656

## Technical data

### General

Test for substances that would hinder coating with paint or varnish	VW PV 3.10.7:2005-02
Result	Test passed
Test specification weathering-resistance	Following ISO 4892-2:2013-03
Test duration	96 h
Result of weather resistance test	Test passed
Salt spray test specification	DIN EN 60068-2-11:2000-02
Procedure	A
Test duration	96 h
Salt spray testing result	Test passed
Wipe resistance of test specification inscriptions	DIN EN 61010-1 (VDE 0411-1):2011-07
Result of wipe resistance test	Test passed
Marking mounting type	screw, rivet

### Standards and Regulations

Wipe resistance	DIN EN 61010-1 (VDE 0411-1)
-----------------	-----------------------------

## Drawings

Dimensional drawing

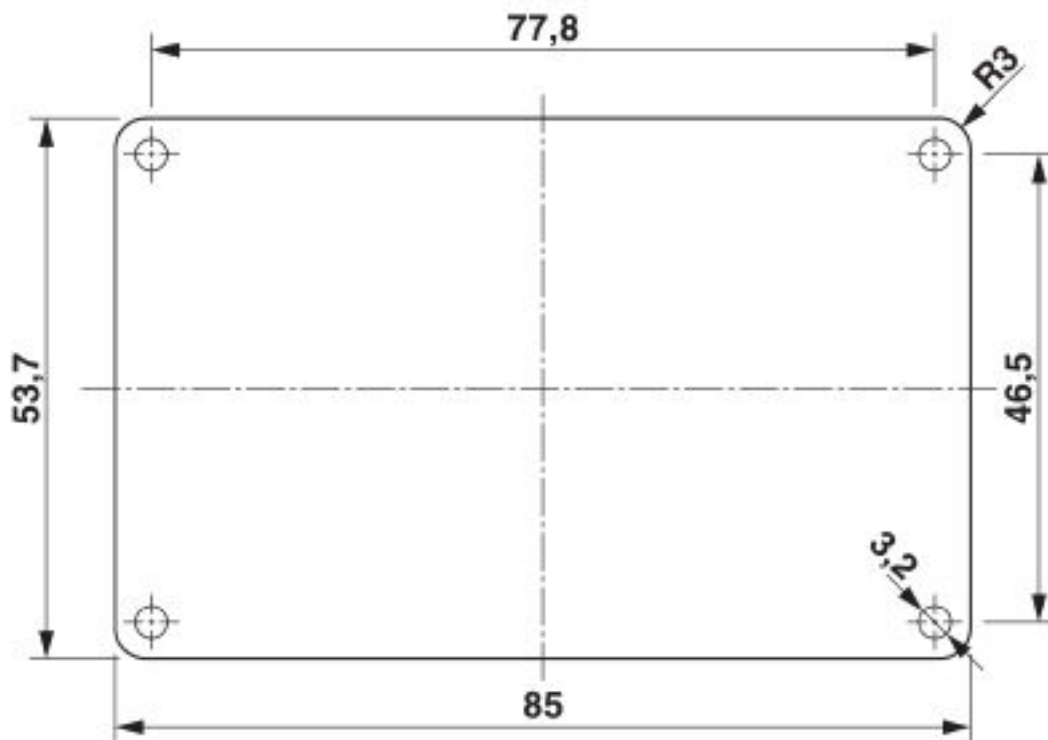

## Device marker - LS-EMSP-V4A (75,6X54) - 0831656

### Classifications

#### eCl@ss

eCl@ss 10.0.1	27400629
eCl@ss 5.0	27149100
eCl@ss 5.1	27141100
eCl@ss 6.0	27149100
eCl@ss 7.0	27149129
eCl@ss 8.0	27149129
eCl@ss 9.0	27400629

#### ETIM

ETIM 4.0	EC000761
ETIM 5.0	EC001288
ETIM 6.0	EC001288
ETIM 7.0	EC001288

#### UNSPSC

UNSPSC 13.2	39131504
UNSPSC 18.0	39131504
UNSPSC 19.0	39131504
UNSPSC 20.0	39131504
UNSPSC 21.0	39131504

### Accessories

#### Accessories

#### Magazine

Magazine - TOPMARK LASER-MAG SHEET - 0831836

Sheet magazine for TOPMARK LASER



#### Printing system

Laser marker - TOPMARK NEO SET - 1012018



Laser marker incl. extraction unit, includes operating instructions, declaration of conformity, LS adapter plate, type E and F power cables, LAN cable, D-SUB cable 25-pos., suction tube, crevice nozzle set and filter equipment

Phoenix Contact 2020 © - all rights reserved  
<http://www.phoenixcontact.com>

PHOENIX CONTACT GmbH & Co. KG  
Flachmarktstr. 8  
32825 Blomberg  
Germany  
Tel. +49 5235 300  
Fax +49 5235 3 41200  
<http://www.phoenixcontact.com>